

# DHB Series

## DHB 830C 7D6

Technical datasheet



**DEREIKE**



### Dereike blower performance curves

#### Vacuum selection diagram curve

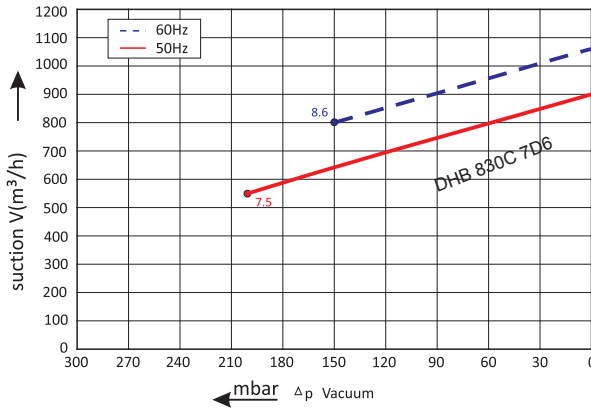

#### Compressor selection diagram curve

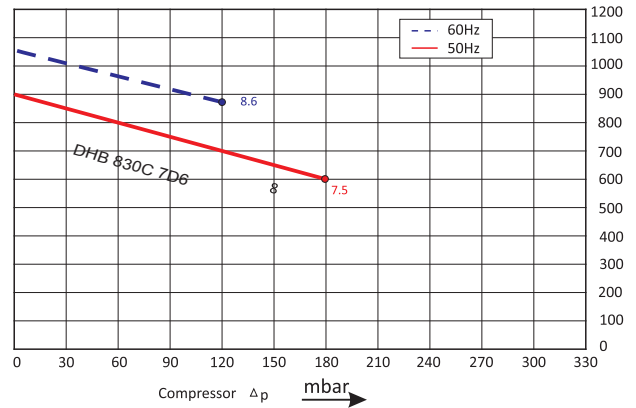

### Dereike blower installation drawing

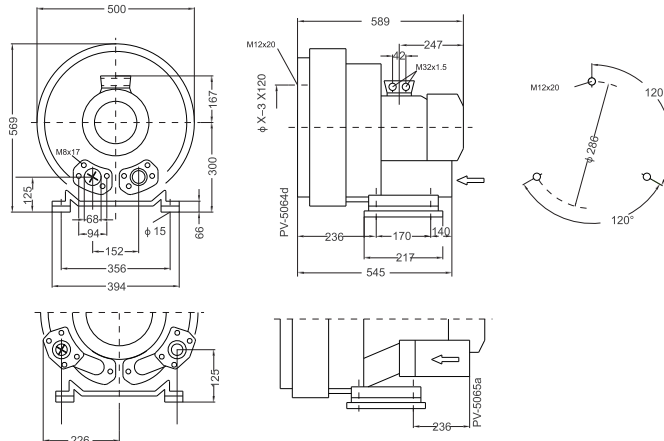

### Dereike blower installation parameter

Model	Frequency	Output	Voltage	Current	Airflow	Pressure		Noise	Weight
						vacuum mbar	compressor mbar		
DHB 830C 7D6	50	7.5	345-415△/600-690Y	16.7△/9.6Y	900	-200	180	74	91
	60	8.6	380-480△/660-720Y	17.3△/10.0Y	1050	-150	120	78	91

The performance curves of Dereike blower is tested through below ways:

Under one atmospheric pressure, suck 15°C air and then you can calculate the data, of course allow 10% difference, and when the sucked air and surroundings temperature are not higher than 25°C, you still can get total pressure difference as the curves shows.