

# DHBT Series

## DHBT 320B 1D1

Technical datasheet



### Dereike blower performance curves

#### Vacuum selection diagram curve

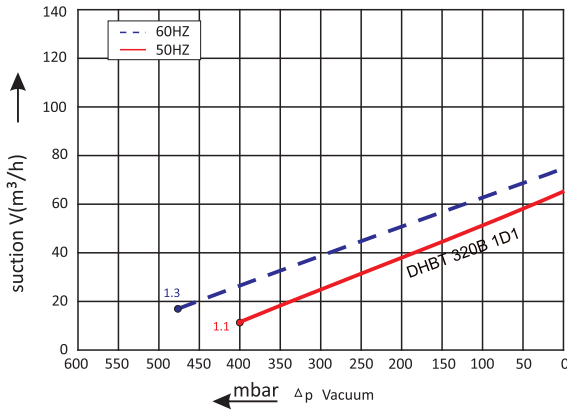

#### Compressor selection diagram curve

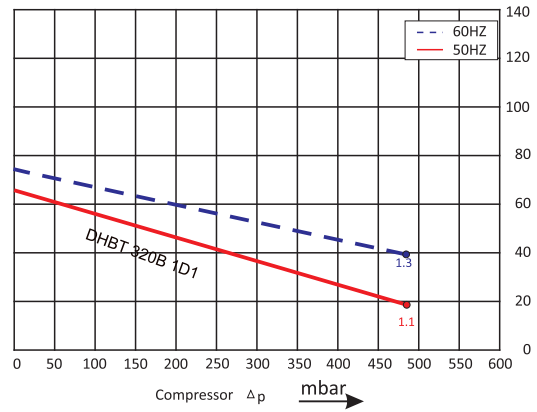

### Dereike blower installation drawing

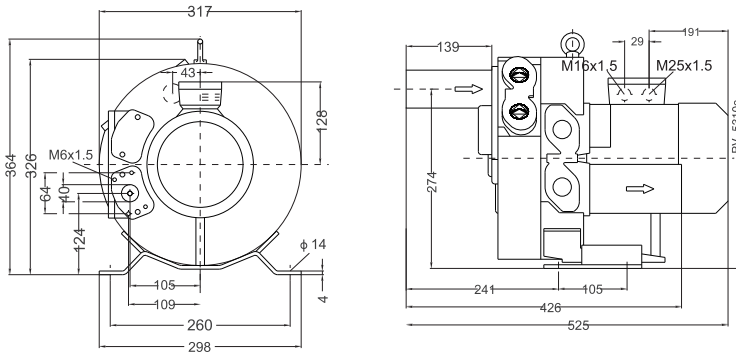

### Dereike blower installation parameter

Model	Frequency	Output	Voltage	Current	Airflow	Pressure		Noise	Weight
						vacuum mbar	compressor mbar		
DHBT 320B 1D1	50	1.1	200-240△/345-415Y	5.4△/3.1Y	65	-400	480	59	29
	60	1.3	220-275△/380-480Y	5.4△/3.1Y	76	-480	480	63	29

The performance curves of Dereike blower is tested through below ways:

Under one atmospheric pressure, suck 15°C air and then you can calculate the data, of course allow 10% difference, and when the sucked air and surroundings temperature are not higher than 25°C, you still can get total pressure difference as the curves shows.